

Italian Journal of Linguistics Rivista di Linguistica

Volume 25, Issue 1 (2013)

Table of Contents

- 1 **Delia Bentley, Francesco Maria Cicone & Silvio Cruschina** (guest-editors). Existential constructions in cross-linguistic perspective
- 15 **Delia Bentley, Francesco Maria Cicone & Silvio Cruschina.** Microvariation in subject agreement: The case of existential pivots with split focus in Romance
- 45 **Lutz Marten.** Structure and interpretation in Swahili existential constructions
- 75 **Eva-Maria Remberger.** Deontic Existentials
- 107 **Ljuba Veselinova.** Negative existentials: A cross-linguistic study
- 147 **Xavier Villalba.** Eventive existentials in Catalan and the topic-focus articulation

Italian Journal of Linguistics Rivista di Linguistica

Editors

Pier Marco Bertinetto (Scuola Normale Superiore, Pisa), Mark Aronoff (Stony Brook University), Michele Loporcaro (Universität Zürich)

Editorial Board (2013)

Giorgio Banti (Università di Napoli "L'Orientale"), Anna Cardinaletti (Università Ca' Foscari di Venezia), Carlo Cecchetto (Università di Milano "La Bicocca"), Gennaro Chierchia (Harvard University), Denis Delfitto (Università di Verona), Edward Flemming (MIT), Livio Gaeta (Università di Torino), Tom Güldemann (Humboldt Universität Berlin), Martin Haspelmath (Max Plank Institut für Evolutionäre Anthropologie, Leipzig), Ekkehardt König (Freie Universität Berlin), Bernard Laks (Université Paris X), Alessandro Lenci (Università di Pisa), Maria-Rosa Lloret Romanach (Universitat de Barcelona), Lori Repetti (SUNY, Stony Brook), Davide Ricca (Torino), Mario Squartini (Università di Torino), Donca Steriade (MIT), Fernando Zúñiga (Universität Bern).

Advisory Board (2013)

Federico Albano Leoni (Università di Roma "La Sapienza"), Henning Andersen (U.C.L.A.), Delia Bentley (University of Manchester), Wolfgang U. Dressler (Universität Wien), R.M.W. Dixon (James Cook University), Katarzyna Dziubalska-Kolaczyk (Poznań University), Larry Hyman (University of California, Berkeley), Adam Ledgeway (University of Cambridge), Alberto Mioni (Università di Padova), Mair Parry (University of Bristol), Domenico Silvestri (Università di Napoli "L'Orientale"), John Charles Smith (University of Oxford), Harro Stammerjohann (Frankfurt am Main).

Editorial Assistants (2013)

Anna Alexandrova, Chiara Celata, Simona Di Paola, Marta Ghio, Giovanna Lenoci, Rosalba Nodari, Emanuele Saiu

Publication information

Italian Journal of Linguistics / Rivista di Linguistica is a peer-review journal addressing all relevant aspects of linguistics, broadly construed, comparing different schools and methods. It seeks to bridge the gap between descriptive and theoretical research. In particular, by often hosting thematic issues, the journal provides a forum for the discussion of specific topics from a variety of points of view.

Periodicity: twice a year.

ISSN 1120-2726

Author enquiries

Correspondence concerning contributions and editorial matters should be addressed to: Pier Marco Bertinetto, Redazione di Italian Journal of Linguistics / Rivista di Linguistica, Scuola Normale Superiore, Piazza dei Cavalieri, 7 - 56126 Pisa, Italy (phone: +39/050/509111; fax +39/050/563513; e-mail: bertinetto@sns.it).

The style-sheet is available at <http://linguistica.sns.it/RdL/ItalianJournalofLinguistics.htm>

Orders and journal enquiries

Subscription rates for 2013: Italy € 80,00; elsewhere € 90,00 (packing and surface mail postage included). Advance payments required.

All communications concerning subscriptions should be addressed to the Publisher: Pacini Editore – via Gherardesca, 1 – 56121 Ospedaletto (Pisa), Italy (phone +39/050/313011; fax: +39/050/3130300; website: www.pacineditore.it).

Autorizzazione del Tribunale di Torino n. 3948 del 9.6.1988; direttore responsabile: Pier Marco Bertinetto.

Impaginazione e stampa: Pacini Editore – Ospedaletto (Pisa).

Publicato con il contributo del CNR.

Existential constructions in crosslinguistic perspective

Delia Bentley, Francesco Maria Cicone & Silvio Cruschina

1. Introduction

Existential constructions are constructions with non-canonical morphosyntax which express a proposition about the existence or the presence of someone or something in a context (Francez 2007, McNally 2011: 1830). They are formed as in (1).

(1) (Expletive) (proform) (copula) pivot (coda)

Following a tradition which is well established in the semantic literature, we use the term PIVOT to refer to the noun phrase which, in English existentials, occurs in immediately post-copular position. The pivot can be followed by a CODA, i.e., an addition, for example a locative phrase. The existential constructions of some languages also exhibit a putatively adverbial form, which can be etymologically locative. This is referred to here as the PROFORM. Only the pivot is universally available, and obligatory, in existential constructions. The other components of the construction may not be present. In (2) we provide examples of existentials in English, Italian, French and Spanish. Observe that the Spanish existential copula exhibits a lexicalized postcopular proform (2d).

- (2) a. There are some books on the table (English)
PROFORM COPULA PIVOT CODA
- b. Ci sono dei libri sul tavolo (Italian)
PROFORM be.3PL some books on-the table
- c. Il y a des livres sur la table (French)
EXPLETIVE PROFORM have.3SG some books on the table
- d. Hay unos libros sobre la mesa (Spanish)
have.3SG-PROFORM some books on the table
'There are some books on the table'

The linear order of the components of the existential construction can also vary across languages. Cudas can occur in initial position, as is shown by the following examples from Brazilian Portuguese, where “the locative phrase must be realized in subject position” (Avelar 2009: 169).

- (3) a. No centro da cidade tinha um engarrafamento enorme
in-the-centre of-the city had a traffic jam big
‘There was a big traffic jam in downtown’
- b. Na locadora tem filmes ótimos em promoção
in-the movie store has movies excellent on sale
‘There are excellent movies on sale in the movie store.’

Across languages, the pivot tends not to take the default syntactic position, or the marking, of topics, as is suggested by the contrast between the Japanese construction in (4a), which is an existential construction, and those in (4b-c). Rather, the pivot normally occurs in the position of foci or direct objects.

- (4) a. Koko-ni hon-ga ar-u (Japanese)
here-LOC book.NOM exist(inanimate)-NON-PST
‘There is a book here’
- b. *Koko-ni hon-wa ar-u
here-LOC book-TOP exist(inanimate)-NON-PST
- c. Ano hon-ga koko-ni ar-u
that book.NOM here-LOC exist(inanimate)-NON-PST
‘That book is here’
(Kyoko Toratani, p.c.)

In the languages which do not exhibit fixed word order in existential constructions, the variation in word order tends to correlate with variation in information structure.

Within an influential syntactic approach, the existential structure is a reduced sentence expressing a subject-predicate relation (Stowell 1978, Chomsky 1981, Safir 1982, Moro 1997), the coda being the predicate of the construction. According to this approach, the existential structure is a SMALL CLAUSE, and the underlying structure of an existential is the same as that of a copular sentence (Freeze 1992).¹

- (5) *be* [SC PIVOT_{SUBJECT} CODA_{PREDICATE}]

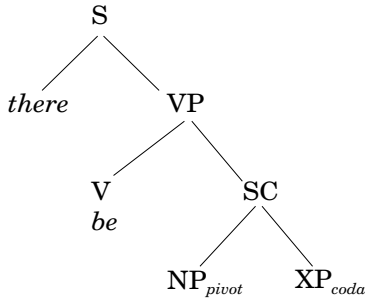

In some studies, a Predicate Phrase (PP) is formally used to represent the predicate relation assumed to hold in the existential construction (Freeze 1992), although this account shares the principal insights of the small-clause analysis. On the other hand, in other syntactic analyses, the coda has been analysed either as a VP adjunct (McNally 1992, Francez 2007, 2009) (cf. (6a)) or as a post-nominal modifier (Barwise and Cooper 1981, Williams 1994) (cf. (6b)).

- (6) a.

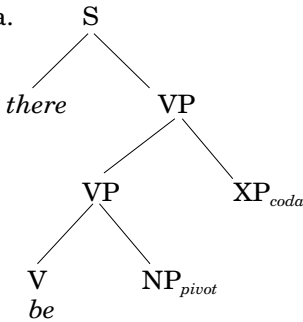

- b.

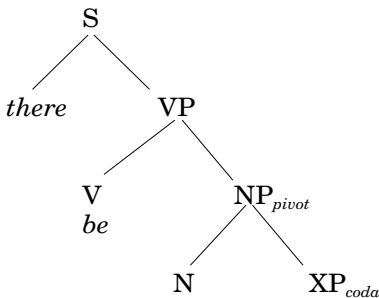

The accounts illustrated in (6a-b) are inspired by the view that existentials are impersonal constructions with an expletive subject and with the pivot as an argument of an existential verb (Milsark 1974, Williams 1984). We return to these accounts below. The syntactic role of the coda in a particular type of existentials, i.e. eventives (Leonetti 2008), is the object of Villalba's contribution to this volume.

2. Theoretical background and open questions

Existential constructions have received a great deal of attention since Milsark (1974). The bulk of the research has investigated the constraints on the pivot or definiteness effects (henceforth DEs). Two principal hypotheses have been advanced. The first is the idea that existentials are impersonal structures (Milsark 1974, 1977, 1979, Perlmutter 1983) in which the pivot must be indefinite because it is an object in object position (subjects are not indefinite). The second is the view that existentials are locative structures (Freeze 1992) whereby definite noun phrases must move to the pre-copular position, thus leaving the post-copular position solely available for indefinite pivots (see **there are the students*, with unstressed *there*, which is ungrammatical in most contexts). Freeze's (1992) view extends to possessive predications, which, like existentials, are claimed to derive from the same underlying locative structure. The Swahili data analysed by Marten in this volume highlight some degree of relatedness between existential, locative and possessive structures. The analysis of negative existentials offered by Veselinova, however, suggests that existential sentences and locative predications are separate constructions.

Both the impersonal and the locative hypotheses seek to explain the DEs in terms of the syntactic position of the pivot. They are thus challenged by any DEs that do not reduce to the syntactic position of this noun phrase. In archaic Campidanese and in Nuorese and Logudorese Sardinian, both definite and indefinite pivots are allowed. However, definite pivots co-occur with the reflex of ESSE 'be', and control agreement on this copula (7a), whereas indefinite pivots normally co-occur with invariant HABERE 'have' (7b). The Sardinian DEs were first investigated by La Fauci & Loporcaro (1993, 1997), who claimed that impersonality does not depend on the position of the noun phrase *per se*, but rather on the combination of indefiniteness and the post-copular position.

- (7) a. Bi sun sas piseddas (Logudorese: Bono)
PF be.3PL the girls
'There are the girls'
- b. B' at medas piseddas
PF have.3SG many girls
'There are many girls'

Subsequent work on the Sardinian DEs has indicated that there are systematic deviations from the expected pattern, i.e., that the default agreeing copula *ESSE* is not only selected with definite pivots but also with classes of putatively indefinite ones, as shown by the examples below.

- (8) a. B' est solu un dischente in iscola (Nuorese: Orosei)
PF be.3SG only a student in school
'There is only one student in the school'
- b. No ddu est / (n)c' est nemus. (Campidanese: Sardara)
not PF be.3SG PF be.3SG nobody
'There is nobody'

These findings suggest that, whilst being morpho-syntactically encoded, the DEs are semantically and pragmatically determined (Bentley 2004, 2010, 2011).

The relatedness between the DEs and the semantics of the subject is the focus of work by Beaver, Francez & Levinson (2005), which in turn draws upon Mikkelsen (2002). Starting from the findings of the typological literature (Clark 1978), Beaver, Francez & Levinson (2006) observed that, across languages, existential constructions differ from canonical copular sentences in several ways: word order, copula selection, locative proforms, verb agreement, etc. These differences correlate with a contrast between the semantic properties of pivots and those of the subject of canonical copular constructions: noun phrases are realized as existential pivots when they lack properties that would make them good subjects. The competition between canonical copular constructions and existential constructions is thus claimed to be the essence of the DEs, which are gradient, rather than categorical, and are defined by the probability of occurrence of a hierarchy of noun phrase classes in subject or pivot function. The language specific interaction of markedness constraints on the subject determines the crosslinguistic variation in the DEs. This is the topic of Bentley, Ciconte & Cruschina's contribution to this volume, which focuses on Italo-Romance, and draws upon Bentley (in press).

Francez (2007, 2009, 2010) shifts the focus of research on existential constructions to the following question: what kinds of proposition do existential sentences express? The proposed solution is that existentials (*There be NP_{pivot} XP_{coda}*) are context-dependent propositions where the pivot is a Generalized Quantifier, and hence a predicate, whereas the coda is a modifier providing the scope of quantification.² Within this account, the DEs arise from the analysis of pivots as predicates, since predicates are by default focal. Noun phrases with properties of topics are blocked from occurring in the construction, if there is a truth-conditionally equivalent proposition in which they are topics rather than foci (Francez 2007: 99). Accordingly, the DEs are not the core issue in the analysis of existential sentences, but rather an epiphenomenon of their semantics.

Despite the size of the existing literature on existential constructions, which we barely touched upon in the above discussion, there remain a number of open questions. We can only mention some here. First, can Francez's (2007) semantic analysis of the pivot as a predicate be extended to constructions of the form *There be definite NP_{pivot} XP_{coda}*? Indeed, are such structures to be analysed as existential sentences? It has been suggested that these constructions must be construed as locative structures in order to be deemed to be grammatical by native speakers (see Moro 1997: 154 and Zamparelli 2000: 69, 196-200 for Italian, and Remberger 2009 for Sardinian). The contrast between existentials and locative predications, i.e., structures of the type *The NP be LocP*, has received some attention both in the semantic literature (Koontz-Garboden 2009, Leonetti 2008: 136, Zamparelli 2000: 69, 196-200) and in the typological one (Dryer 2000: 242-243). In the semantic literature it has been argued that existentials can be diagnosed distinct in truth conditions from locatives (Koontz-Garboden 2009). However, broad crosslinguistic analysis suggests that there are languages which do not formally differentiate between structures which presuppose existence and structures which assert or deny it (Dryer 2000: 243, Koch 2012, Levinson 2006, cf. (9)), and the rationale of the contrast between the grammars which do and those which do not is to date poorly understood.

- (9) Kémi kîgha kapî k:oo ka tóó. (Yélí Dnye)
 mango fruit cup in DEICTIC.TAM sits
 'The ripe mango is in the cup / There is a mango in the cup.'
 (Levinson 2006:165, 177)

Drawing upon Leonetti (2008), Cruschina (2012) suggests that, at least in Italo-Romance, the structures illustrated in (10a-b) should be distinguished.

- (10) a. There be definite NP, XP_{coda}
b. There be indefinite NP XP_{coda}

In (10a), the definite noun phrase is the focal argument of an INVERSE LOCATIVE predication, i.e., a predication with a topical locative predicate, which is separated from the rest of the clause by a pause. The proform is a locative resumptive propredicate clitic. Contrastingly, the structure in (10b) is an existential construction proper, where the indefinite noun phrase is the predicate, while the proform is a proargument spelling out a non referential topic that provides the contextual domain of the existential predication (Francez 2007, Parry 2010, Pinto 1997, Tortora 1997).

The view that, in (10a), the proform retains its original locative function is supported by the analysis of early Italo-Romance sources (Ciconte 2009, 2011). Latin, the mother of Italo-Romance, did not have a proform in existential constructions.

- (11) Est modus in rebus, sunt certi fines (Latin)
be.3SG measure.NOM in things be.3PL certain.NOM boundaries.NOM
'There is a measure in things, there are some boundaries'
(Horace, *Sermones*, 1, 1, 106-107)

The emergence of the proform in early Italo-Romance (13th-15th century Tuscan) is attested first in unmistakably locative predications with a focal definite argument, where the proform is referential and occurs in complementary distribution with a locative phrase. Only at a later stage (16th century) is the proform generalized to genuine existential constructions with an indefinite pivot, where the proform is not in complementary distribution with a locative phrase. Some valuable insights on Romance proforms are offered by Remberger in this volume.

A further type of pseudo-existential, which is referred to as PRESENTATIONAL in Cruschina (2012), is characterized by a special coda, which does not modify the sentence in locational terms, but rather introduces a subject-predicate relation into discourse.

- (12) a. C'è tuo fratello che ti aspetta da un'ora
PF be.3SG your brother who 2SG.OBJ.CL wait.3SG since one hour
'Your brother has been waiting here for you for an hour'
(lit.: 'There's your brother that has been waiting for you for an hour')
- b. C'è Mario che si è fatto male
PF be.3SG Mario who REFL be.3SG done bad
'Mario hurt himself' (lit.: 'There's Mario who has hurt himself')

Presentational sentences are not existential constructions. In fact, they are not subject to definiteness restrictions (see (12a-b)), they may lack locative anchoring, and the noun phrase does not have predicate properties, but rather is introduced as the subject of the subsequent predication (Cruschina 2012: 98). Some of the issues related to this construction in Catalan are addressed by Villalba in this volume.

The attention to existentials and related issues is still very much alive in the current international research arena, as witnessed by workshops devoted to these topics (for example, the workshop on Definiteness Effects organized as part of the 2012 Annual Conference of the German Linguistic Society, *Jahrestagung der Deutschen Gesellschaft für Sprachwissenschaft*, DGfS, Frankfurt, March 2012). Peculiarly, there are only very few recent collections of papers specifically devoted to existential constructions. One such a volume is *Existence. Semantics and Syntax*, edited by Comorovski's and Heusinger (2007), which stems from a workshop held at the University of Nancy in September 2002. Despite its title, this volume mainly concentrates on the semantics of the construction, and only few chapters adopt a crosslinguistic perspective. In the spirit of Beaver, Francez and Levinson (2005), we hope that this thematic issue of the *Italian Journal of Linguistics* will begin to fill this regrettable lacuna by broadening the horizons of the existing research to micro- and macro-variation in existential constructions.

3. Scope and structure of the volume

This thematic volume is the first output of a project entitled *Existential constructions: An investigation into the Italo-Romance dialects* (www.manchester.ac.uk/existentials, Arts and Humanities Research Council, grant AH/H032509/1). The objectives of the project are both theoretical, as we seek to shed new light on the discourse-semantics-morphosyntax interface in existentials, and empirical,

in that we aim to create an atlas of the existential constructions of Italo-Romance, to be understood here in the broad sense of Romance dialects spoken in Italy. To test our hypotheses, we conducted extensive fieldwork in Italy, interviewing speakers of 138 dialects. Our body of data is available on our website in a set of streaming media audio-files. Whereas the principal focus of the project is on micro-variation in a family of closely cognate languages, in June 2012 we hosted a symposium (*The Manchester Symposium on Existentials*), which aimed to stimulate theoretical debate in the light of novel evidence from as wide a range of languages as possible. In this issue, we include a selection of the papers from the symposium, in accordance with a trajectory which spans from micro-variation to macro-variation. The volume is thus structured as follows.

Bentley, Ciconte and Cruschina examine the micro-variation in the control of finite (number) agreement on the copula by the pivot of existential constructions, arguing that this depends on the variation in the tolerance of marked subjects. Following a tenet of Optimality Theory, the authors understand SUBJECT MARKEDNESS as the relation between a discrete syntactic function and its semantic and pragmatic correlates. A class of pivots which proves to be particularly resilient to the control of agreement is the class which exhibits cliticization with an outcome of Latin INDE ‘of it’, ‘of them’. The markedness of these pivots as subjects is claimed to depend on the lack of topicality, specificity, and argumentality, the three properties which are relevant to subjecthood across Italo-Romance, as well as the split focus structure involved in INDE-cliticization.

The problem of the coda in existential sentences is addressed by Xavier Villalba, who investigates eventive existentials in Catalan (Cruschina’s 2012 presentational pseudo-existentials). Villalba defends a VP adjunct analysis of codas in eventive existentials, against the recent claim that this type of existential should be analysed as involving a small clause (Leonetti 2008). In support of his hypothesis, Villalba provides a robust set of tests regarding the structural relation between the pivot and the coda and their respective information status. Ultimately, the author concludes that both the pivot and the coda are part of the assertion, while the topic of the existential sentence is represented by a null stage topic. In addition to clarifying and highlighting structural and semantic aspects of eventive existentials, this paper paves the way for further study of the role of the coda in existential sentences.

Existential constructions are better understood in comparison to constructions that exploit the same grammatical elements

and have developed similar meanings. This is the aim of Eva-Maria Remberger's contribution, which analyses DEONTIC EXISTENTIALS (e.g., Italian *ci vuole il pane* 'we need bread', lit. 'there wants the bread') in synchronic and diachronic perspective. In Italian and some dialects of Italy, this special deontic type of existential consists of a modal verb (corresponding to English 'want'), and an obligatory etymologically locative element which is identical to the proform of the canonical existential construction. Deontic existentials resemble canonical existentials in many other respects: definiteness effects, the postverbal position of the noun phrase and the agreement between this noun phrase and the finite verb, or lack thereof. On the basis of these parallels, and building upon an existing tradition of study (Remberger 2009, Cruschina 2012), Remberger claims that a distinction must be drawn between deontic existentials proper, featuring an indefinite pivot, and deontic locatives, which are characterized by a definite noun phrase.

Lutz Marten's paper shifts the focus of the discussion to a different language family, describing and comparing the existential constructions of Swahili. The main interest of these constructions lies in their sharing of morphosyntactic properties with other structures, namely possessives and locatives, which have often been associated with existentiality. Two principal types of existential construction are available in Swahili: the LOCATIVE-POSSESSIVE CONSTRUCTION, formed with a possessive copula and a locative subject marker, and the LOCATIVE-COPULA CONSTRUCTION, involving a locative copula and a non-locative subject. Marten shows that, whilst expressing existentiality, these constructions are distinguished by several structural and interpretive differences. He further notes the possibility of adding a predicative clausal complement to the focussed post-copular noun phrase of both existential constructions. The resulting structure resembles ordinary constructions with post-copular noun phrases modified by a relative clause, but it crucially lacks relative clause marking. Comparable structures are found in unrelated languages, such as English and German, and indeed Italo-Romance presentationals featuring a pseudo-relative clause (cf. 12).

Lastly, Veselinova offers a typological account of negation in existential constructions, capturing macro-variation with the aid of semantic maps. Crosslinguistically, EXISTENTIAL NEGATION can be formally distinct from Standard Negation in form, and consistently proves to be different in meaning. Accordingly, negative existentials are claimed to constitute a grammatical construction of its own, in fact a separate conceptual domain. Given that existential negation is

absolute (it indicates non existence), it is incompatible with locative predications, where the scope of negation is normally constrained to the locative predicate. Veselinova's contribution thus provides a useful test for telling existentials apart from locatives.

We hope that this issue of *Italian Journal of Linguistics* will fruitfully contribute to the debate on existential constructions, ultimately favouring further investigation of these structures in the literature on language typology, semantics, and comparative syntax.

Address of the Authors

School of Arts, Languages and Cultures, The University of Manchester,
Oxford Road, M13 9PL Manchester, Great Britain
<delia.bentley@manchester.ac.uk>
<francescomaria.ciconte@manchester.ac.uk>
<silvio.cruschina@manchester.ac.uk>

Notes

¹ Note that in Moro's (1997) account the coda is not part of the small clause involved in existentials, but is regarded as a VP adjunct. It is instead the (locative) expletive that acts as the predicate of the small clause. This variant of the small clause analysis allows Moro to capture the correlations between existentials and copular sentences in light of his "raising" hypothesis, but leaves open the question of what it means for an expletive to be the predicate of the existential construction (see Francez 2007).

² We should note that although this is the first explicit semantic analysis of pivots as predicates, the hypothesis that pivots are predicates had previously been put forward in the syntactic literature (La Fauci & Loporcaro 1993, 1997, Williams 1994, Zamparelli 2000, Hazout 2004).

Bibliographical References

- AVELAR Juanito 2009. On the emergence of TER as an existential verb in Brazilian Portuguese. In CRISMA Paola & Giuseppe LONGOBARDI (eds.). *Historical Syntax and Linguistic Theory*. Oxford: Oxford University Press.
- BARWISE Jon & Robin COOPER 1981. Generalized quantifiers and natural language. *Linguistics and Philosophy* 4 (2). 159-219.
- BEAVER David, Itamar FRANCEZ & Dmitry LEVINSON 2005. Bad subject: (non-)canonicity and NP distribution in existentials. In GEORGALA Effi & Jonathan HOWELL (eds.). *Proceedings of Semantics and Linguistic Theory (SALT) XV*. Ithaca, NY: CLC Publications. 19-43.

- BENTLEY Delia 2004. Definiteness effects: evidence from Sardinian. *Transactions of the Philological Society* 102. 57-101.
- BENTLEY Delia 2010. Principles of subject markedness in Romance. *Archivio Glottologico Italiano* 95 (2). 152-189.
- BENTLEY Delia 2011. Sui costrutti esistenziali sardi. Effetti di definitezza, deissi, evidenzialità. *Zeitschrift für romanische Philologie* 127 (1). 111-140.
- BENTLEY Delia (in press). Subject canonicality and the definiteness effects in Romance *there* sentences. *Language*.
- CHOMSKY Noam 1981. *Lectures on government and binding*. Dordrecht: Foris.
- CICONE Francesco Maria 2009. Pro-forms in Existential Constructions of Early Italo-Romance Vernaculars. In KAISER Georg & Eva-Maria REMBERGER (eds.). *Null subjects, expletives and locatives in Romance*. Konstanz: Universität Konstanz, Konstanzer Arbeitspapiere des Fachbereichs Sprachwissenschaft (No. 123). 183-198.
- CICONE Francesco Maria 2011. The emergence and the reanalysis of the existential proform: evidence from Early Italo-Romance. *Transactions of the Philological Society* 109 (3). 284-306.
- CLARK Eve 1978. Locationals: Existential, locative, and possessive constructions. In GREENBERG Joseph H., Charles A. FERGUSON & Edith A. MORAVCSIK (eds.). *Universals of human language, Vol. 4*. Stanford, CA: Stanford University Press. 85-126.
- COMOROVSKI Ileana & Klaus HEUSINGER 2007 (eds.). *Existence: Semantics and Syntax*. Dordrecht: Springer.
- CRUSCHINA Silvio 2012. Focus in Existential Sentences. In BIANCHI Valentina & Cristiano CHESI (eds.). *Enjoy Linguistics! Papers offered to Luigi Rizzi on the occasion of his 60th birthday*. Siena: CISCL Press. 77-107.
- DRYER Matthew S. 2000. Clause types. In SHOPEN Timothy (ed.). *Clause Structure, Language Typology and Syntactic Description, Vol. 1*. Second Edition. Cambridge: Cambridge University Press. 224-275.
- FRANCEZ Itamar 2007. *Existential propositions*. Stanford: Stanford University. PhD dissertation.
- FRANCEZ Itamar 2009. Existentials, predication, and modification. *Linguistics and Philosophy* 32. 1-50.
- FRANCEZ Itamar 2010. Context dependence and implicit arguments in existentials. *Linguistics and Philosophy* 33. 11-30.
- FREEZE Ray 1992. Existentials and other locatives. *Language* 68 (3). 553-95.
- HAZOUT Ilan 2004. The syntax of existential constructions. *Linguistic Inquiry* 35. 393-430.
- KOCH Peter 2012. Location, existence, and possession: A constructional-typological exploration. *Linguistics* 50 (3). 533-603.
- KOONTZ-GARBODEN Andrew 2009. Locative and existential constructions in Ulwa. *Anthropological Linguistics* 51 (3-4). 244-268.
- LA FAUCI Nunzio & Michele LOPORCARO 1993. Grammatical relations and syntactic levels in Bonorvese morphosyntax. In BELLETTI Adriana (ed.). *Syntactic Theory and the Dialects of Italy*. Turin: Rosenberg & Sellier. 155-203.
- LA FAUCI Nunzio & Michele LOPORCARO 1997. Outline of a theory of existentials on evidence from Romance. *Studi italiani di linguistica teorica e applicata* 26. 5-55.

- LEONETTI Manuel 2008. Definiteness effects and the role of the coda in existential constructions. In HØEG MÜLLER Henrik & Alex KLINGE (eds.). *Essays on Nominal Determination*. Amsterdam: John Benjamins. 131-162.
- LEVINSON Stephen C. 2006. The language of space in Yéî Dnye. In LEVINSON Stephen C. & David P. WILKINS (eds.). *Grammars of Space. Explorations in Cognitive Diversity*. Cambridge: Cambridge University Press. 157-205.
- MCNALLY Louise 1992. *An Interpretation for the English Existential Construction*. Santa Cruz: University of California, Santa Cruz. PhD dissertation. Published by Garland Press, New York, 1997.
- MCNALLY Louise 2011. Existential sentences. In MAIENBORN Claudia, Klaus VON HEUSINGER & Paul PORTNER (eds.). *Semantics: An International Handbook of Natural Language Meaning*, Volume 2. Berlin: Mouton de Gruyter. 1829-1848.
- MIKKELSEN Line 2002. Reanalyzing the definiteness effect: Evidence from Danish. *Working Papers in Scandinavian Syntax* 69. 1-75.
- MILSARK Gary 1974. *Existential Sentences in English*. Cambridge, Mass.: MIT. PhD dissertation.
- MILSARK Gary 1977. Toward an Explanation of Certain Peculiarities of the Existential Construction in English. *Linguistic Analysis* 3. 1-29.
- MILSARK Gary 1979. *Existential sentences in English*. New York: Garland.
- MORO Andrea 1997. *The Raising of Predicates*. Cambridge: Cambridge University Press.
- PARRY Mair 2010. Non canonical subjects in the early Italian vernaculars. *Archivio Glottologico Italiano* 95 (2). 190-226.
- PERLMUTTER David 1983. Personal versus impersonal constructions. *Natural Language & Linguistic Theory* 1. 141-200.
- PINTO Manuela 1997. *Licensing and Interpretation of Inverted Subjects in Italian*. Utrecht: Universiteit Utrecht. PhD dissertation.
- REMBERGER Eva-Maria 2009. Null subjects, expletives and locatives in Sardinian. In KAISER Georg & Eva-Maria REMBERGER (eds.). *Null subjects, expletives and locatives in Romance*. Konstanzer Arbeitspapiere des Fachbereichs Sprachwissenschaft 123. 231-261.
- SAFIR Ken 1982. *Syntactic Chains and the Definiteness Effect*. Cambridge, Mass.: MIT. PhD dissertation.
- STOWELL Tim 1978. What was there before there was there? In FARKAS Donka et al. (eds.). *Proceedings of the 14th Regional Meeting of the Chicago Linguistics Society*. Chicago: Chicago Linguistic Society. 458-471.
- TORTORA Christina 1997. *The Syntax and Semantics of the Weak Locative*. Delaware: University of Delaware. PhD Dissertation.
- WILLIAMS Edwin 1994. *Thematic Structure in Syntax*. Cambridge, Mass: MIT Press.
- ZAMPARELLI Roberto 2000. *Layers in the Determiner Phrase*. New York: Garland.